

The crowning glory.
The new Salamander from Salvis.



from Franke Food Service Equipment to



The Salamander Vitesse.

A golden-brown topping to tickle your guests' palates in no time at all:

Accessible from all sides. Modular appliance design. Effortless height adjustment.

■ Made to measure

Salvis launches the first Salamander that allows you to work from all sides.

In addition to the design and material qualities that make it easy to clean, the Vitesse from Salvis comes with a host of other refinements. And best of all: thanks to its modular design, you only pay for what you really need in your kitchen. Choose between

- 2 different heating systems (tubular or HiLight heating elements)
- 4 different operating modes, i.e.
- 8 different versions

Its compact dimensions allow you to configure your Vitesse ready for use as a table-top, wall- or ceiling-mounted model with optional grid and fat drip tray.



Basic model

Standard model

Standard Plus model/Max model



Four models – four operating modes ... and every one is simplicity itself to use.



■ The ingeniously designed heat reflector is equipped with a double casing and an intelligent heating system on all models that prevents overheating of the reflector handle. All models have room in the base in which GN sheets and grids can be inserted.

■ Vitesse Standard

The Standard has all the features of the Basic and more besides: one main switch for left, right or full power and hotplate plus:

- mechanical timer for 0–15 minutes, switching-off automatically

■ Vitesse Standard Plus

The right temperature at the right time? Leave the Vitesse Standard Plus to look after your meals. With its two ingenious additional features over the basic version, you can depend on it completely:

- 0–99 minute electronic timer or continuous operation
- electronic program control

■ Vitesse Basic

Even the entry model in the Vitesse line will impress you with its ease of operation and optimum results. One main switch for left, right or full power and hotplate.





■ **Vitesse Max**

The Vitesse Max is the ultimate in user-friendliness. It browns your dishes as though by magic. In addition to the basic functions, it offers the following special features:

- 0–99 minute electronic timer or continuous operation
- electronic program control
- automatic raising and lowering function

■ **Heating systems**

All Vitesse models offer the choice between traditional, inexpensive tubular heating element (RH) and the modern, fast HiLight heating element (HL).

HiLight heating element

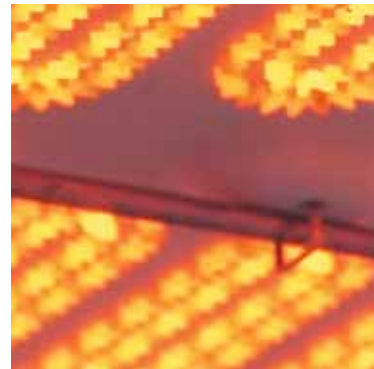

Tubular heating element





■ **A range of installation options**
Can be adapted for installation as
a table, wall or ceiling-mounted model.

Salamander Vitesse for ceiling mounting



Dimensions

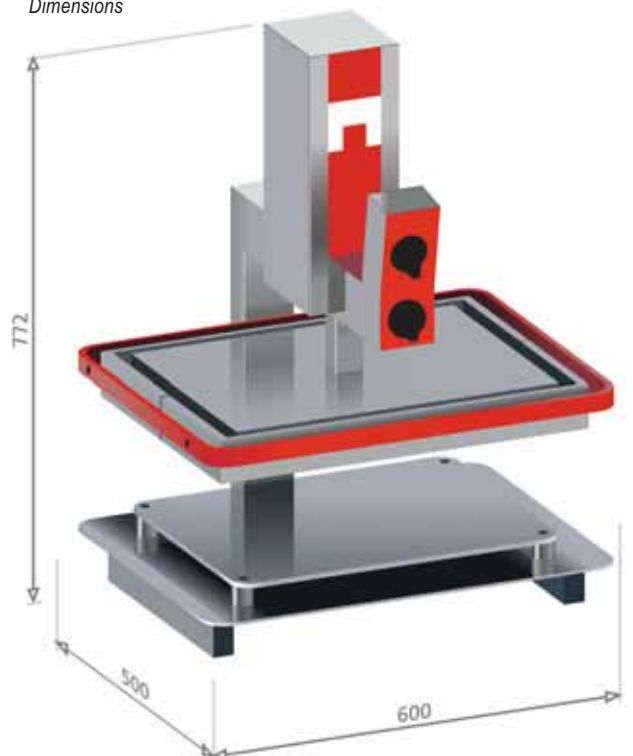

Facts and figures



Technical data

	Basic	Standard	Standard Plus	Max
Tubular heating element version	RH-EM	RH-ET	RH-EE	RH-EH
Part No.	SA 373'100	SA 373'101	SA 373'102	SA 373'103
HiLight heating element version	HL-EM	HL-ET	HL-EE	HL-EH
Part No.	SA 373'104	SA 373'105	SA 373'106	SA 373'107
Voltage / Supply line	400 V 2N AC 50 Hz, 2L+N+PE			
Fuse	10 A	10 A	10 A	10 A
Dimensions LxDxH (mm)	600x500x772			

Power

Type	RH	HL
Full power	4 kW	4,6 kW
Left or right full power	2 kW	2,3 kW
Standby power	1 kW	1,1 kW

RH = Tubular heating element HL = HiLight heating element

Optional accessories

Type	Description	Part. No.
SA-RO	Grid GN 1/1	SA 373'150
SA-AS	Drip tray GN sheet 1/1	SA 373'151
SA-AG	Base plate granite	SA 373'152

Fitting accessories (for all models)

Type	Description	Part. No.
SA-MW	Fitting set for wall mounting	SA 373'153
SA-TS	Heat shield for wall mounting; required for combustible walls	SA 373'154
SA-MD	Fitting set for ceiling mounting	SA 373'155

Whether a grid, drip tray or granite base plate – Salvis has just what you are looking for. You can find everything in the full catalogue.

SALVIS AG

Dorfbachstrasse 2
CH-4663 Aarburg
www.salvis.ch

Telephone +41 62 787 38 38
Telefax +41 62 787 30 01

from Franke Food Service Equipment to

