

PRO 1/2



Gastro Pro
Gastronorm 2 Door
280 Litre Counter

specifications

PRO 1/2



FEATURES & BENEFITS

- Zero ODP refrigerants and insulation
- Energy-saving Hydrocarbon refrigerant option
- Minimal noise output, which is important in certain locations
- High refrigeration specification ensures it works in hot kitchens
- Climate Class 5 rating: 43°C ambient
- Simple to use LED temperature display with operating and safety alarms
- Easy to clean, non-rusting 304 grade stainless steel exterior as standard
- Unique fluted trayslides are easy to guide and prevent shelves from tipping
- Lockable castors for easy positioning and cleaning around the cabinet
- 60mm all round insulation maximises energy efficiency
- Impact resistant, removable PVC thermal break helps maintain temperature difference and offers easy access for servicing. Patent Applied No. 0019596.6
- Fully floating lock keep reduces the chance of accidental breakage. Patent Applied No. 0019598.2
- Removable easy clean condenser filter keeps coil in excellent running condition
- Compact refrigeration system featuring easily removable lid for service access. Patent Applied No. 0019600.6
- Completely removable refrigeration plug - fully replaceable

DIMENSIONS

External Dimensions: 1415 x 700 x 865 (wxdxh) mm
Depth with door open: 1500 mm

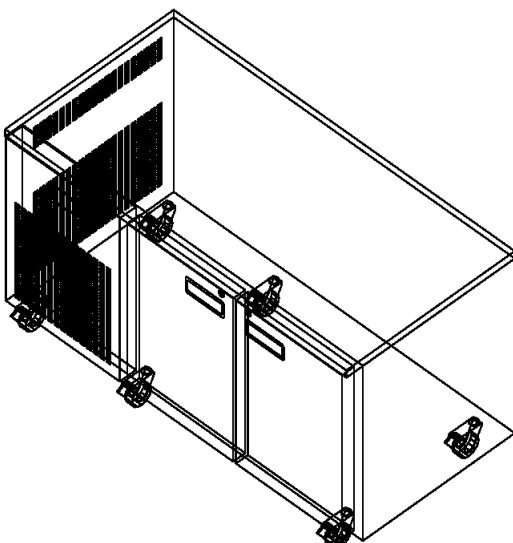

RANGE

Type	Temp. Range
Model No. refrigerator	PRO 1/2 H +1/+4°C
Model No. freezer	PRO 1/2 L -18/-21°C
Model No. meat/chill	PRO 1/2 M -2/+2°C

PRO 1/2



PRO 1/2

TECHNICAL SPECIFICATION

● standard ○ option

FINISH

	PRO 1/2 H	PRO 1/2 L	PRO 1/2 M
304 stainless steel exterior/aluminium interior	●	●	●
304 stainless steel exterior/interior	○	○	○
complete 304 stainless steel back for island siting	○	○	○

FEATURES AND OPTIONS

	PRO 1/2 H	PRO 1/2 L	PRO 1/2 M
number of GN1/1 (325 x 530mm) shelves	4	4	4
full solid door(s)	●	●	●
1/2 Drawers	○	-	-
1/3 Drawers	○	-	-
less worktop (reduces height by 28mm)	○	○	○
splashback	○	○	○
saladette pan cut-out	○	-	-
hinged night cover	○	-	-
door mullion heater	●	●	●
right hand mounted refrigeration unit	○	○	○
electric condensate heater	○	○	○
helicoil mains lead	○	○	○
castors 80mm	●	●	●
castors 100mm	○	○	○
150mm or 100mm legs***	○	○	○
levelling bolts	○	○	○
additional nylon coated shelf (GN 1/1)	○	○	○
nylon coated basket (GN 1/1)	○	○	○
integral remote	●	●	●

SERVICE INFO

	PRO 1/2 H	PRO 1/2 L	PRO 1/2 M
dec ratings (decibels)****	57.5	62.5	57.5
refrigerant R134a	●	-	●
refrigerant R404a	-	●	-
refrigerant R290 (Hydrocarbon)*****	○	○	○
thermal heat rejection	324	379	288
230v	●	●	●
50Hz	○	○	○
60Hz*****	○	○	○
1Phase	●	●	●
watts	296	450	330
amps	2.1	3.2	2.4
fuse	10	10	10
drain*****	●	●	-
approx. weights (kgs)	167	167	167

****Measured 1m high from the floor and 1m out from the cabinet.



Foster Refrigerator
 Oldmedow Road
 King's Lynn
 Norfolk PE30 4JU
 Tel: 01553 698466
 Fax: 01553 772504
 Email: projects@foster-uk.com
 www.fosterrefrigerator.co.uk