



ITEM NO.

# MJ45 and MJ45-2 Gas Fryers

AA File No. 35-C111

Specifically designed for high-volume frying



Shown with optional computer and casters

- Open-pot design, no tubes, easy to clean
- Durable centerline thermostat
- 7-to-10 second response to loads, 1° anticipating action, reduced temperature overshoot
- Deep cold zone, 1-1/4 in. (32 mm) IPS ball-type drain valve
- Master Jet burner, no burner tube radiants to burn out, no cleaning or adjusting air shutters
- Rounded corners for easy-to-clean “Euro” look

The MJ45 has a minimum 40-lbs. (20 liters)\* and maximum 50-lbs. (25 liters)\* shortening capacity. The frying area is 14 x 15 in. (356 x 381 mm) at shortening level. This 122,000 BTU/hr. (30,730 kCal/hr.) (35.8 kW) model is specifically designed for high-volume frying. The exclusive 1° action thermostat anticipates rapid rate of temperature rise, reducing temperature overshoot, extending shortening life and producing a more uniformly-cooked product. Centerline thermostat mounting permits quick sensing (7 to 10 seconds) of cold food placed in either basket. Multiple orifice burner has no burner tube radiants to burn out. No burner cleaning or air shutter adjustment is required. The open stainless steel frypot has a large heat transfer area to fry more product per load. The open-pot design has no hard-to-clean tubes. Every inch of the frypot and cold zone can be cleaned and wiped down by hand.

The large cold zone catches crumbs and sediment from the frying area. These particles are trapped in the cold zone where they do not carbonize, contaminate shortening or cling to fried products.

The MJ45 and MJ45G models use a millivolt temperature control circuit. The MJ45GBL automatic basket lift motor uses 120V (230V or 240V for CE/Export). The MJ45E model uses a 120V (220V-240V for export) supply system to accommodate additional accessories. Shortening melt cycle controls, automatic basket lifts and Filter Magic PRO® or FootPrint PRO® systems are available. Up to six fryers can be battered to the right side of a FootPrint PRO® system. Filter Magic PRO® is available underneath one (up to six) full-sized fryer and contains a spreader. The spreader can include an optional heat lamp and dump station. The heat lamp can be a choice of rod style or bulb type. The dump stations can use either cafeteria-style or scoop-type pan. The heat lamp and pans are integrated into the cabinet, making a complete warming station. The solid-state controls, electronic ignition and melt cycle are available.

Each side of the MJ45-2 split pot fryer operates on 63,500 BTU/hr. (15,995 kcal/hr.) (18.6 kW), has a maximum shortening capacity of 25 lbs. (12 liters) and has a frying area of 6-1/2 x 15 inches (165 x 381 mm). The fryer has all of the features and options of the MJ45 and gives the operator the discretion of using only half the fryer.

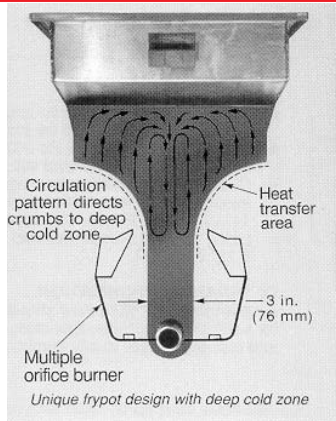

Liter conversions are for solid shortening @ 70°F.



ISO 9001:2000



CALL FACTORY

Frymaster, L. L. C.

8700 Line Avenue, P. O. Box 51000, Shreveport, Louisiana 71135-1000, USA, Phone 318-865-1711

TOLL FREE 1-800-221-4583 Fax 318-868-5987, www.frymaster.com

Distributed in Canada by GARLAND COMMERCIAL RANGES, LTD., 1177 Kamato, Mississauga, Ontario L4W 1X4

# MJ45 and MJ45-2 Gas Fryers

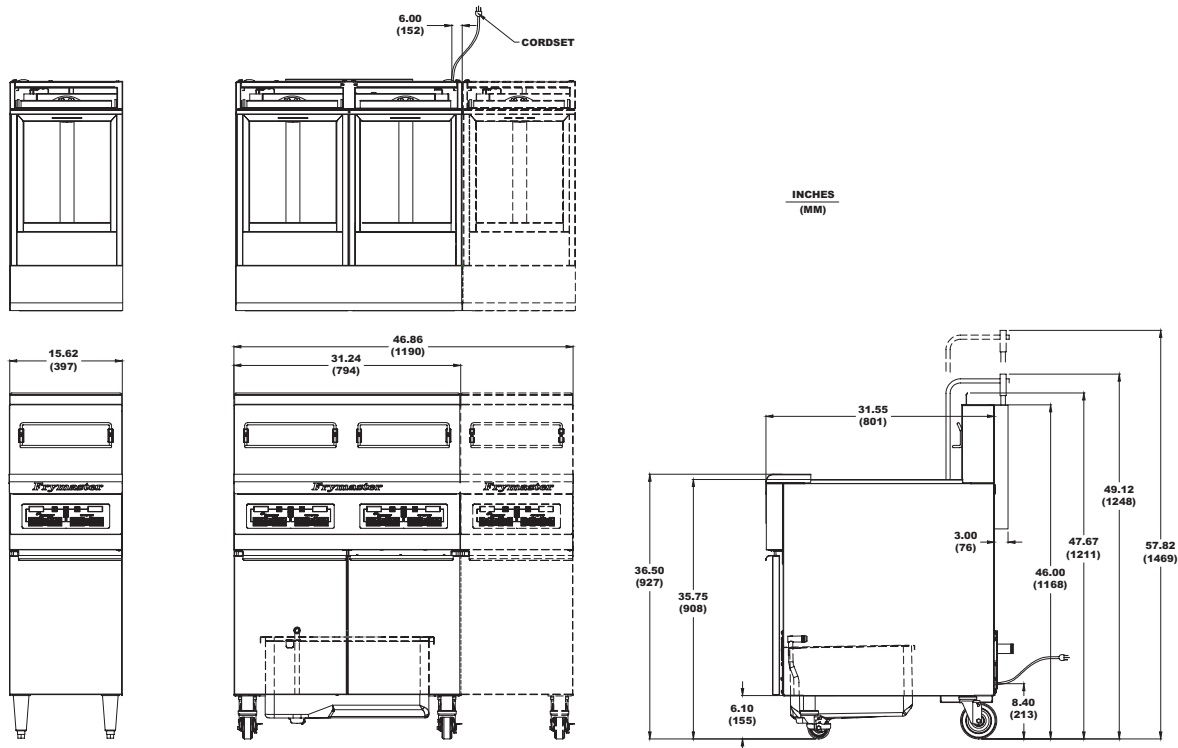

## DIMENSIONS

STYLE	SHORTENING CAPACITY MIN. - MAX.	OVERALL SIZE (MM)			DRAIN HEIGHT (MM)	NET WEIGHT	APPROXIMATE SHIPPING DIMENSIONS (MM)					
		HEIGHT	WIDTH	LENGTH			WEIGHT	CLASS	CUBE	DIMENSIONS		
Without Basket Lifts	40-50 lbs. (20-25 liters)	46" (1168)	15.62" (397)	31.55" (801)	10.61 (269)	145 lbs. (66 kg)	177 lbs. (80 kg)	85	19.47	H 46.5" (1080)	W 22" (559)	L 36" (914)
With Basket Lifts	40-50 lbs. (20-25 liters)	49.12" (1248)	15.62" (397)	34.55" (878)	10.61 (269)	185 lbs. (84 kg)	233 lbs. (107 kg)	85	19.47	46.5" (1080)	22" (559)	36" (914)

## POWER REQUIREMENTS

MODEL NO.	NATURAL GAS	LP GAS	ELECTRICAL	EXPORT
PMJ45 (-2) PMJ45G (-2)	122,000 BTU/hr. input (30,730 kcal/hr.) (35.8 kW)	122,000 BTU/hr. input (30,730 kcal/hr.) (35.8 kW)	none required for millivolt system	
All Other Models	122,000 BTU/hr. input (30,730 kcal/hr.) (35.8 kW)	122,000 BTU/hr. input (30,730 kcal/hr.) (35.8 kW)	120V/60 Hz	240V/50 Hz 3-1/2 Amps 230V/50 Hz 2 Amps (CE)

## GAS FRYER SPECIFICATION

**Description:** Fryer shall be an open-pot floor model type, capable of cooking a minimum of 80 lbs. of frozen french fries per hour. The frypot is to be constructed of cold rolled or stainless steel (each optional). Full pot will have a capacity of 40-50 lbs. (20-25 liters) of shortening, with a 14 x 15 inch (356 x 381 mm) frying area; split pot will have a capacity of 20-25 lbs (10-12 liters) of shortening with a 6-1/2 x 14 inch (165 x 381 mm) frying area. The frypot shall have a large cold zone without tubes for easy cleaning. The unit is to be provided with a 1-1/4" IPS ball-type drain valve (full pot)/1" IPS ball-type drain valve (split pot), located 10.6 inches from the floor. The unit is to be provided with two heavy gauge fry baskets with insulated handles.

The burner system is to incorporate an atmospheric burner with multiple orifices rated at 122,000 BTU/hr. The burner system is to be controlled by a centerline mounted thermostat with a 1° temperature sensing accuracy. Unit to be equipped with a high-limit safety thermostat.

The unit shall be built and listed to NSF, AGA, CGA and CE standards.

The fryer is to carry a one-year limited warranty on parts and labor with a lifetime limited warranty on the stainless frypot. The operating thermostat is to be Fenwal type and carry a two-year limited warranty.

Model supplied to this specification shall be a Frymaster type MJ45/MJ45-2.

## NOTES

- 3/4" (NPT) gas inlet size for single fryers; for 2 or more fryers, a 1" supply line should be provided.
- Supply voltage 120V 60 Hz – Control Voltage 24V 60 Hz. 120 VAC 5 ft. (1.5 m) grounded cord set.
- Check plumbing codes for proper supply line sizing. Recommended minimum store manifold pressure to be 6" W.C. for natural gas and 11" W.C. for L.P. gas. Check plumbing codes for proper supply line sizing to attain burner manifold pressure of 3.5" W.C. natural or 8.25" W.C. L.P.

## CLEARANCE INFORMATION

A minimum of 24" (610 mm) should be provided at the front of the unit for servicing and proper operation, and 6" (152 mm) between the sides and rear of the fryer to any combustible material.

## OPTIONAL ACCESSORIES

- Computer, basket lift timer, digital or solid state controller
- Electronic ignition (must use one of the above controllers)
- Frypot cover
- Sediment tray
- Full size basket in lieu of twin baskets
- Fryer's Friend clean-out rod
- Screen-type basket support
- Fishplate
- Piezo ignitor
- Shortening melt cycle control
- 3/4" x 48" (19 x 1219 mm) quick disconnect with gas line and adapter
- 3/4" x 36" (19 x 914 mm) quick disconnect with gas line and adapter
- Automatic basket lifts (2 independent lifts with 0-15 minute mechanical timers)
- Stainless steel apron drain with basket (interchangeable right or left side)
- 0-15 minute mechanical timer (G model only)

**Enodis**  
One Company. Countless Solutions.

**Frymaster, L. L. C.**

8700 Line Avenue, P. O. Box 51000, Shreveport, Louisiana 71135-1000, USA, Phone 318-865-1711

**TOLL FREE 1-800-221-4583** Fax 318-868-5987, [www.frymaster.com](http://www.frymaster.com)

Distributed in Canada by **GARLAND COMMERCIAL RANGES, LTD.**, 1177 Kamato, Mississauga, Ontario L4W 1X4