

**HL-17025K & HL-17040K**

**80, 100 Liter Mixer**

**FEATURE :**

- \* As life safety guard, the mixer is automatically shut off to meet safety requirement. The mixer does only work when the safety guard is down. Stainless steel grid guard is standard.
- \* High efficiency two-speed assures complete blending dough to give positive results within 15 minutes every time.
- \* Positive timers, automatically control mixing time. One for slow speed and the other one for high speed. In case of timers failure, machine still can run with special switch.
- \* New, special mixing technology, synchronized speed with reverse turning bowl, intensively kneads dough downward keep dough cooler and higher efficiency effects.
- \* Positive spiral mixing provides dough with water absorption ability and much more volume to assure more uniform texture.
- \* Powerful, long life motor itself can change speed, without shifting gears, with minimum maintenance required.
- \* Bowl has two rotary directions available, forward and backward.
- \* Strong Stainless steel spiral-agitator, guide bar, and bowl are designed to meet baking industry sanitation standard.
- \* 2 heavy duty motors, one to drive spiral, one to drive bowl.



**HL-17025K**



**HL-17040K**

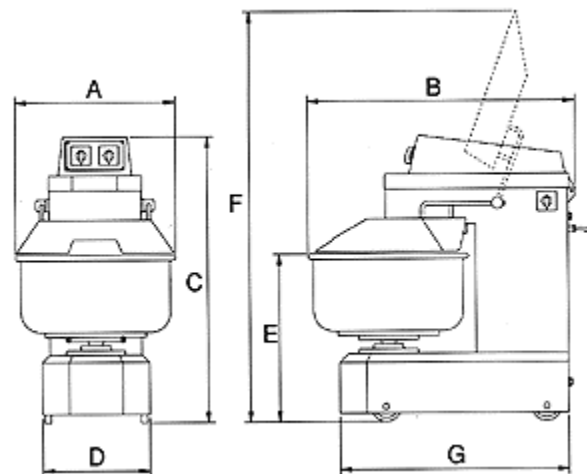

**Specifications :**

	Capacity			Dimensions (mm)					Net Weight	Motors	
		Dough	Bowl	A	B	C	D	E		Arm	Bowl
HL-17025K	30kg	50kg	80L	1140	550	1040	780	1470	400kg	3HP	1HP
HL-17040K	45kg	70kg	100L	1140	660	1040	810	1520	450kg	4HP	1.5HP

- \* Any three phase is available, please specify voltage when ordering.
- \* Due to product improvement, specifications are subject to change without notice.

