

PLANETARY MIXER

BM10

10 Liter Mixer

Features :

- * Small commercial grade
- * Table model
- * Timing belt transmission
- * Easy speed-shifting
- * Three fixed speed
- * Heavy duty construction
- * Powerful motor

Optional Accessories :

- * C-type Hook
- * 15 Min. Timer
- * Safety Guard with micro switch
- * Scraper

Standard Accessories :

- * Spiral Dough Arm
- * Flat Beater
- * Wire Whip
- * 10 Liter Bowl



BM10

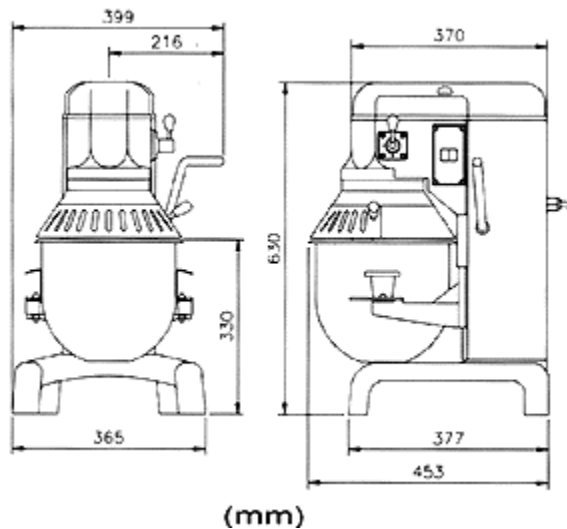

BM10A

Specifications :

Model Mo.	Bowl Capacity	Motor	Agitator Speed (RPM)			15 Min. Timer	Safety Guard	N.W.
	10 Liter	1/3HP 0.25 Kw	60-cycle motor			---	---	60kg
BM10T			135	243	478	Std.	---	132Lbs.
BM10A			50-cycle motor			---	Std.	62kg
BM10AT			113	203	400	Std.	Std.	136.4Lbs.

T-15 Min. Timer A-Safety Guard

- * Any voltage is available, please specify voltage and phase when ordering.
- * Due to product improvement, specifications are subject to change without notice.