

HL-17010K 40 Liter Mixer

FEATURE :

- * Powerful two-motor designed, one to drive spiral arm, one to drive bowl.
- * High efficiency two-speed gives positive results of dough mixing.
- * Bowl has two rotary directions available, forward and backward.
- * Stainless steel spiral agitator is made 25% thicker than those of the industry's leader for increased durability and strength.
- * There is an overload relay to protect motor and transmission components.
- * Stainless steel safety guard is standard. As lift safety guard, the mixer's limit-switch is automatically shut off to protect operator.
- * Mixers are baked coated with long lasting and chip-resistant paint enamel.



HL-17010K

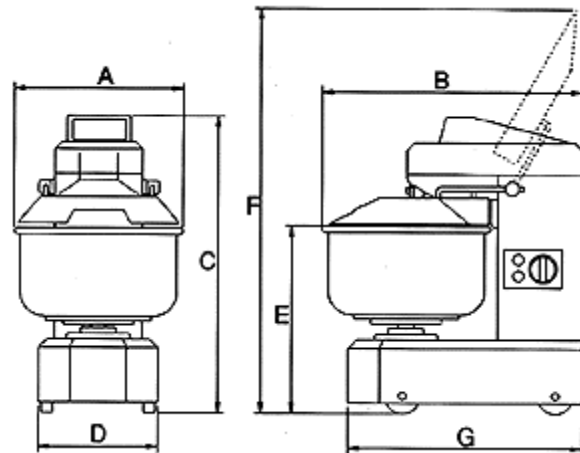

Specifications :

| | Capacity | | | Dimensions (mm) | | | | | | | Net Weight | Motors | |
|-----------|----------|------|-----|-----------------|-----|-----|-----|-----|------|-----|------------|--------|-------|
| | Dough | Bowl | | A | B | C | D | E | F | G | | Arm | Bowl |
| HL-17010K | 12kg | 20kg | 40L | 480 | 740 | 850 | 340 | 530 | 1150 | 670 | 150kg | 1.5HP | 1/3HP |