



Item # \_\_\_\_\_  
Project \_\_\_\_\_  
Date \_\_\_\_\_

## Model # D15 Single Bowl Premix Dispensers



### Features

- Super strong, virtually unbreakable bowls and covers
- Rounded bowl corners for easier cleaning
- Two-piece stainless dispensing valves - sanitary and drip-free!
- Choose standard 5 gallon (18.5 liter) bowl or optional 3 gallon (11 liter) bowl.
- Agitators are included for fresh juices, coffees or teas
- Available in regular (-4) or all stainless (-3) style
- Choose 115V/60Hz, 230V/50Hz or 230V/60Hz
- Optional Whipper for frothed drinks



GRINDMASTER CRATHCO SYSTEMS, INC.

*"Global Customer Satisfaction"*

Grindmaster® Coffee Grinders and Brewers • Espresso® Espresso Machines • Crathco® Hot Beverage Dispensers  
Crathco® Cold and Frozen Beverage Dispensers • American Metal Ware® Coffee and Tea Systems

Tel (502) 425-4776 • Fax (502) 425-4664 • 1-800-695-4500

P.O. Box 35020 • Louisville, KY 40232 • USA

www.gcsworld.com • email: info@gcsworld.com

# Model # D15 Single Bowl

## Premix Dispensers

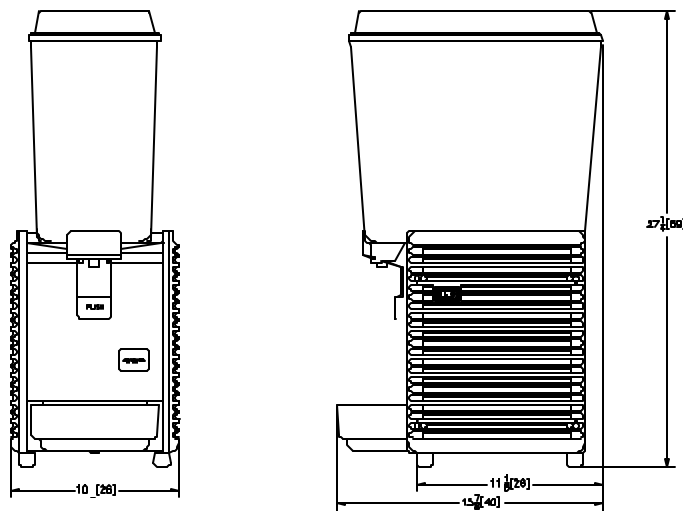

Specifications	D15	D155	D156
# Bowls	1	1	1
Bowl Capacity	5 gallons (18.9L)	5 gallons (18.9L)	5 gallons (18.9L)
Refrigeration	1/6 hp	1/6 hp	1/6 hp
Volts / Hz / Amps	115V / 60Hz / 3Amp	230V / 50Hz / 1.5Amp	230V / 60Hz / 1.5Amp
Dimensions (H x W x D)	27 1/4" x 10" x 15 7/8" (69 cm x 25 cm x 39 cm)	27 1/4" x 10" x 15 7/8" (69 cm x 25 cm x 39 cm)	27 1/4" x 10" x 15 7/8" (69 cm x 25 cm x 39 cm)
Dimensions w/ Whipper (H x W x D)	29 3/4" x 10" x 15 7/8" (76 cm x 25 cm x 39 cm)	29 3/4" x 10" x 15 7/8" (76 cm x 25 cm x 39 cm)	29 3/4" x 10" x 15 7/8" (76 cm x 25 cm x 39 cm)
Ship Weight	46 lbs (20.4 kg)	46 lbs (20.4 kg)	46 lbs (20.4 kg)
Ship Weight w/ Whipper	50 lbs (22.7 kg)	50 lbs (22.7 kg)	50 lbs (22.7 kg)
Cup Height	8 1/4" (20.3 cm)	8 1/4" (20.3 cm)	8 1/4" (20.3 cm)
Cup Height w/ Whipper	5 1/2" (12.7 cm)	5 1/2" (12.7 cm)	5 1/2" (12.7 cm)
Listings	UL, NSF, CUL	NSF, CE	NSF, CE

Options*	Single Models
Side panels & drip trays	-3 Stainless steel material (additional charge), -4 off-white high impact plastic (standard - no additional charge)
3 gallon (11.3L) Bowls	3 gallon (11.3 liter bowl)
Frosted Bowls 5 gal. (18.9L), 3 gal. (11.3L)	Frosted surface simulates condensation while helping hide product residue and offering added UV protection.
Frosted Lid	Lid with frosted surface for use with 3 gallon (11.3L) or 5 gallon (18.9L) frosted bowls
Valve cap (part# 2039)	Improves sealing of valve when using pulpy products
Valve locking box (part# 2502) (use w/ standard handle)	Secures the valve from dispensing during off-hours - not to be used with non-contact handle
Liquid Auto Fill (part# 90295)	Ensures proper product and mixing consistency, maintains optimum product level in bowls, eliminates need for frequent manual mixing
Shipboard kit (part# 5925)	Makes unit safer for installation aboard marine vessel; only available for use with agitator
Milk Fat Impellers	Use with milkbased products, and/or products with heavy pulp
Whippers (must be ordered when ordering machine), add W before model number	Great for iced cappuccinos and iced coffee. Whips beverage upon dispensing to create a frothy top on drink.

\*Extra cost for options listed above

Specifications are subject to improvement or change without notice.

Ask about the Grindmaster Crathco Systems' line of Coffee Grinders, Coffee Brewers, Coffee Urns, Coffee Shuttles, Coffee Grinderbrewers, Espresso Grinders, Espresso Brewers, Beverage Dispensers, Granita Machines and Beverage Freezers.



Grindmaster® Coffee Grinders and Brewers • Espresso® Espresso Machines • Crathco® Hot Beverage Dispensers  
Crathco® Cold and Frozen Beverage Dispensers • American Metal Ware® Coffee and Tea Systems

Tel (502) 425-4776 • Fax (502) 425-4664 • 1-800-695-4500  
P.O. Box 35020 • Louisville, KY 40232 • USA  
www.gcsworld.com • email: info@gcsworld.com